

EAST-WEST

CYCLING CORRIDOR PROJECT

STAKEHOLDER PRESENTATION
MAY 28, 2020



PROJECT AGENDA

1. East-West Corridor
2. Goals and Guiding Principles
3. Benefits of Active Transportation
4. Design Considerations
5. Vodden Street
6. Howden Boulevard
7. Hanover Road
8. Project Timeframe
9. Public Consultation
10. Next Steps



EAST-WEST CORRIDOR

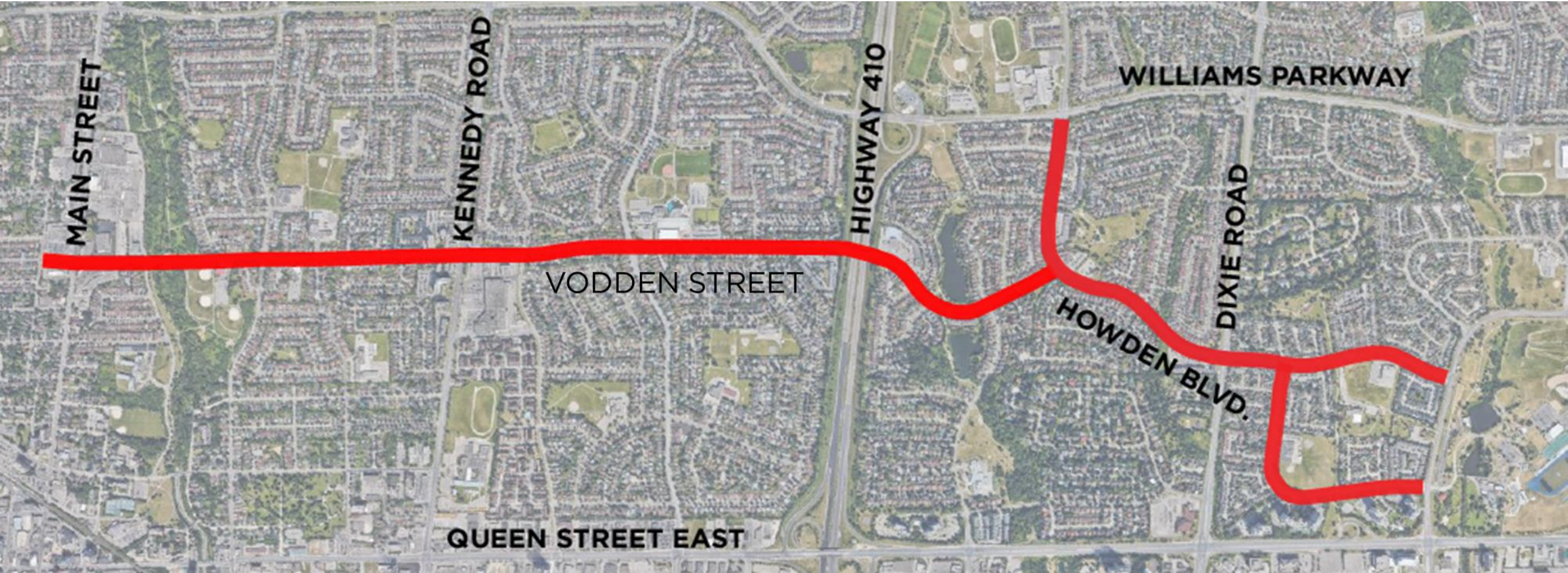

EAST-WEST CORRIDOR



PROJECT GOALS AND GUIDING PRINCIPLES

Introduce new physically separated bike lanes

Reallocate roadway space to accommodate cycling infrastructure

Reduce vehicle speeds along the study area

Integrate the separated bike lanes with existing trails and bike lanes

BROADER MUNICIPAL VISION

BRAMPTON 2040 VISION

“In 2040, Brampton will be a mosaic of safe, integrated transportation choices and new modes, contributing to civic sustainability, and emphasizing walking, cycling, and transit.”

BRAMPTON IS A GREEN CITY

Priorities:

1. Equalize all forms of transportation
2. Implement a green framework
3. Sustainable growth
4. Lead environmental innovation

BRAMPTON IS A HEALTHY AND SAFE CITY

Priorities:

1. Community partnerships
2. Streets for people
3. Local health solutions
4. Healthy citizens

BENEFITS OF A.T.



IMPROVES HEALTH

Encourages physical activity, combating obesity, type 2 diabetes, and cardiovascular disease



PROVIDES CHOICE

Offers greater flexibility in how people may choose to get around



LOWERS EMISSIONS

Eliminates emissions generated by motor vehicles that exacerbate air pollution and climate change



OPTIMIZES TRAFFIC

Diverts car trips, providing traffic capacity to accommodate essential motorized travel (e.g. emergency, transit, deliveries)



ENHANCES ROAD SAFETY

Ensures the protection of all travel modes particularly, those most vulnerable (e.g. cyclists and pedestrians)



SUSTAINABLE DEVELOPMENT

Supports active and sustainable lifestyles by providing facilities that allow people to feel comfortable

DESIGN CONSIDERATIONS

REDUCE MOTOR VEHICLE SPEEDS

- Design a traffic-calmed east-west corridor
- Reduce the width of vehicle travel lanes compared to lane widths that exist today
- High vehicle speeds has been a concern for local residents

IMPLEMENT A ROAD-DIET

- Due to excess capacity on Vodden Street, Hanover Road, and a segment of Howden Boulevard, remove 1 vehicle travel lane per direction
- Add centre left-turn lane to improve access for vehicles turning into residential and commercial driveways

PROVIDE PHYSICAL SEPARATION FOR CYCLISTS

- Provide horizontal and vertical separation between bikes and motor vehicles
- Use of precast concrete curbs and flexible bollards to physically separate bike lanes from motor vehicles

ACCOMMODATE USERS OFF-ROAD ALONG HOWDEN BOULEVARD

- Due to existing traffic volumes along Howden Boulevard, an in-boulevard facility is preferred to an on-road separated bike lane
- Accommodates users of all ages and abilities
- Sufficient space in boulevard to accommodate the facility

DESIGN CONSIDERATIONS

PHYSICAL SEPARATION



FLEXIBLE BOLLARDS

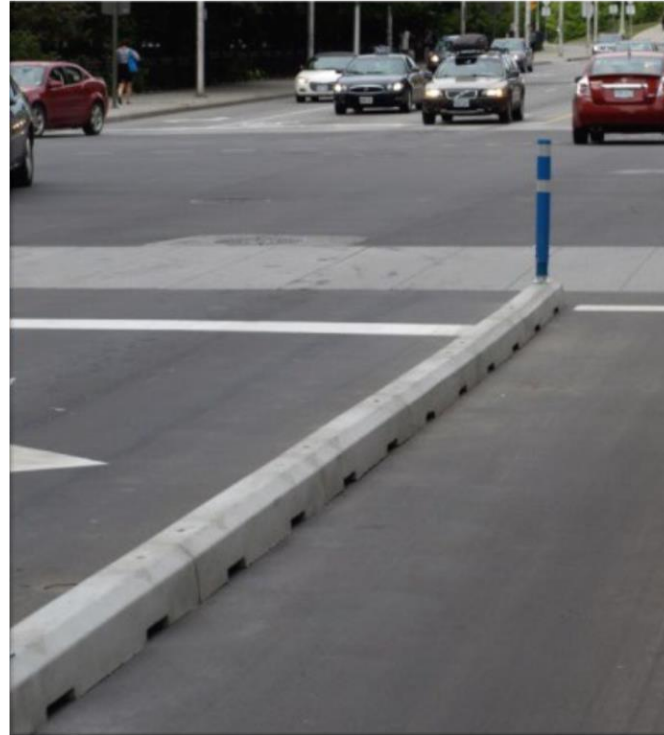

PRECAST CONCRETE CURBS



**PRECAST CONCRETE CURBS
WITH FLEXIBLE BOLLARDS**

DESIGN CONSIDERATIONS

BUS STOP TREATMENTS

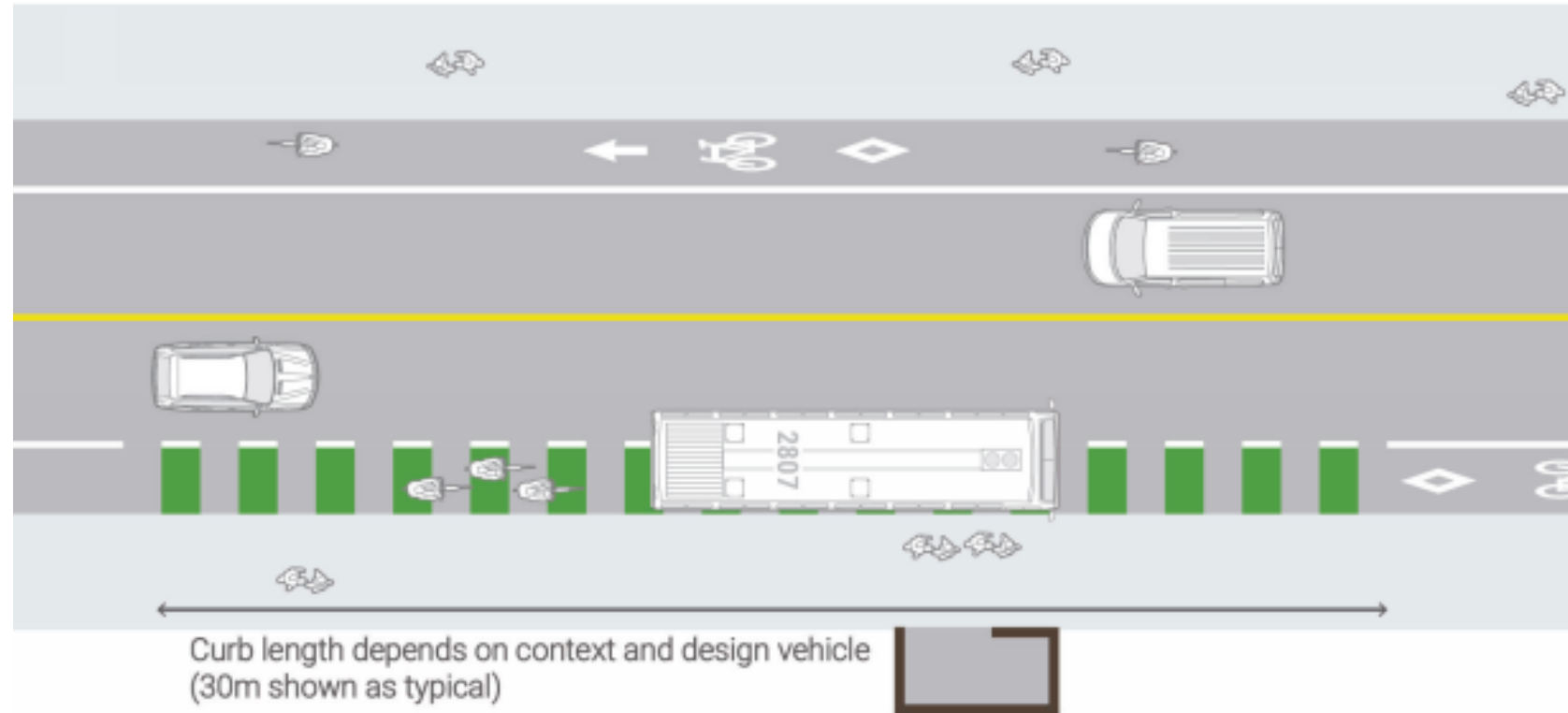

DESIGN HIGHLIGHTS

- **Dashed green pavement markings**
Identify locations where a bus is expected to encroach into the bike lane
- **Buffer Reallocation**
Avoid creating transit bays by shifting the buffer width to the opposite side of the road
- **Maintain curbside operations**

DESIGN CONSIDERATIONS

BUS STOP TREATMENTS

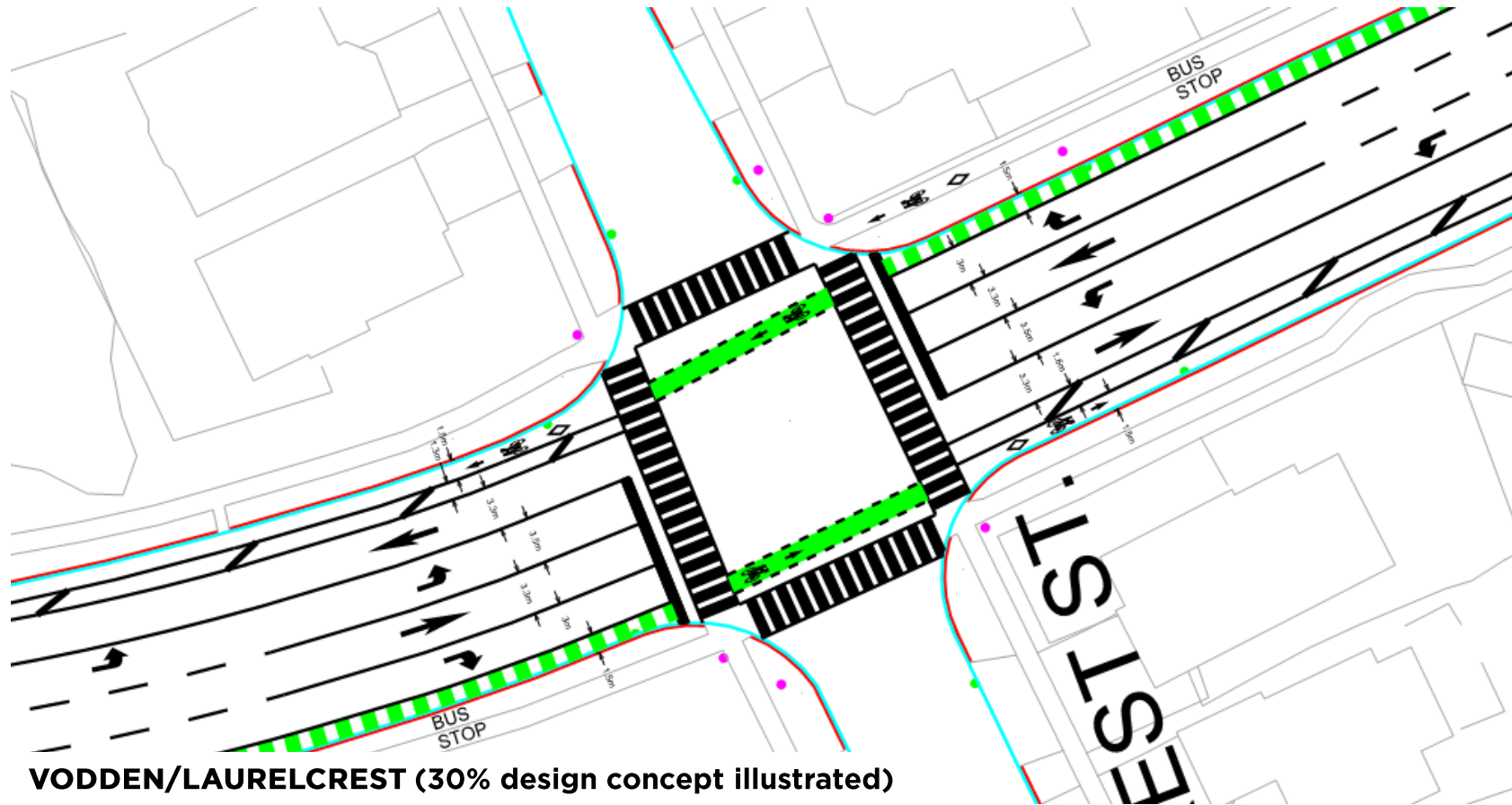

DESIGN HIGHLIGHTS (Vodden/Laurelcrest Bus Stops)

- Dashed green pavement markings
- Buffer width reallocation
- Maintain curbside operations
- Bus to partially block dedicated right-turn lane, ensuring turning vehicles cannot pass when stopped

DESIGN CONSIDERATIONS

INTERSECTION TREATMENTS

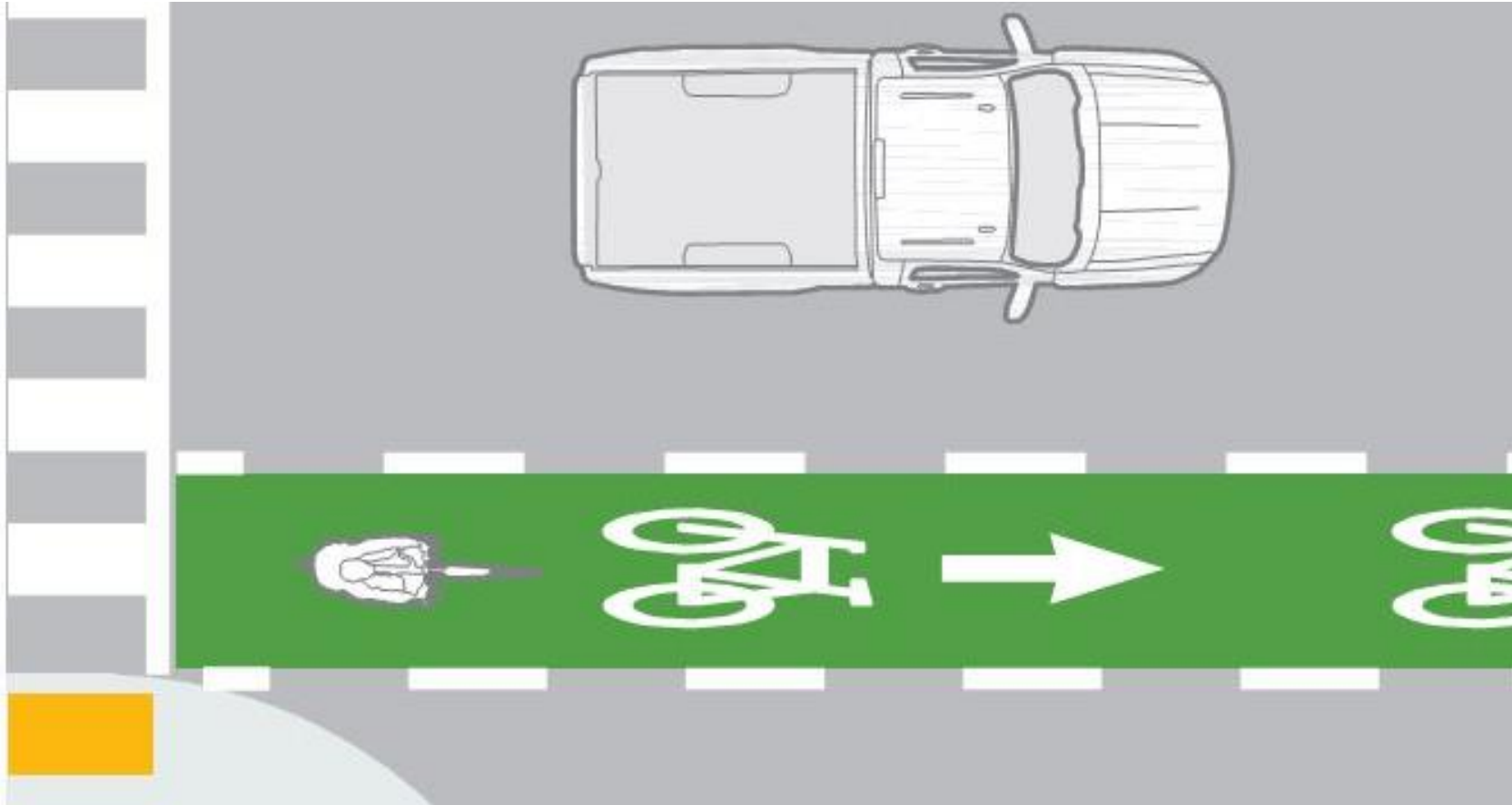

DESIGN HIGHLIGHTS (Signalized Intersections)

- **Solid green surface treatment**
Identifies a conflict zone where the motor vehicle and cycling paths of travel intersect
- **Dashed Guide Lines**
Provide guidance to people cycling through an intersection. Treatment includes directional arrow and bicycle stencil

DESIGN CONSIDERATIONS

INTERSECTION TREATMENTS

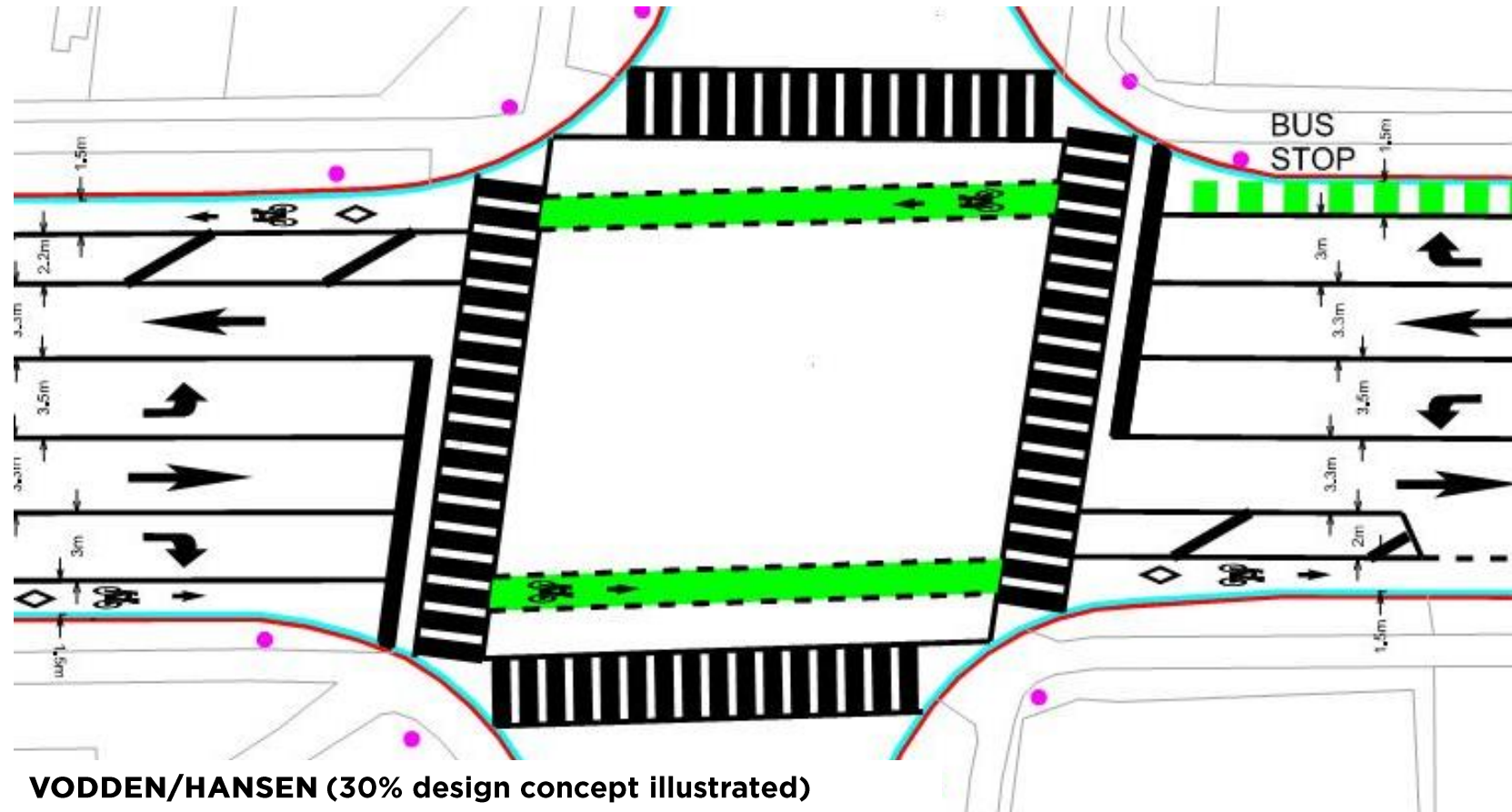

DESIGN HIGHLIGHTS (Vodden/Hansen)

- Solid green surface treatment
- Dashed guide lines
- Offset buffer to accommodate bus stop treatment
- Introduction of new right-turn lanes

DESIGN CONSIDERATIONS

INTERSECTION TREATMENTS

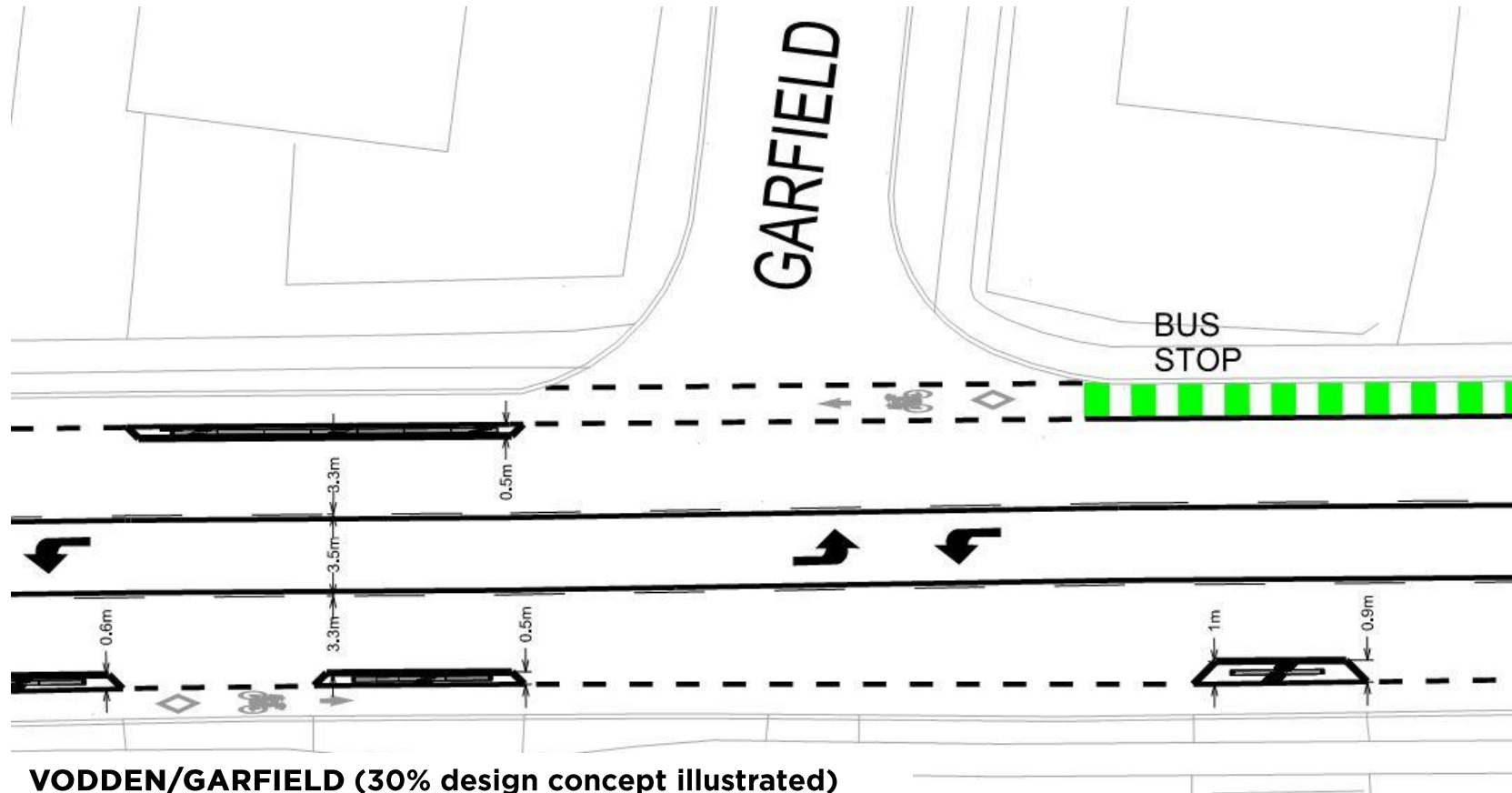

DESIGN HIGHLIGHTS (Unsignalized Intersections)

- **Directional Arrow, Bicycle Stencil, and Diamond**
Directional guidance for cyclists
- **Dashed Guide Lines**
Provide guidance to people cycling through an intersection, denoting the cycling path

DESIGN CONSIDERATIONS

VODDEN/MAIN INTERSECTION

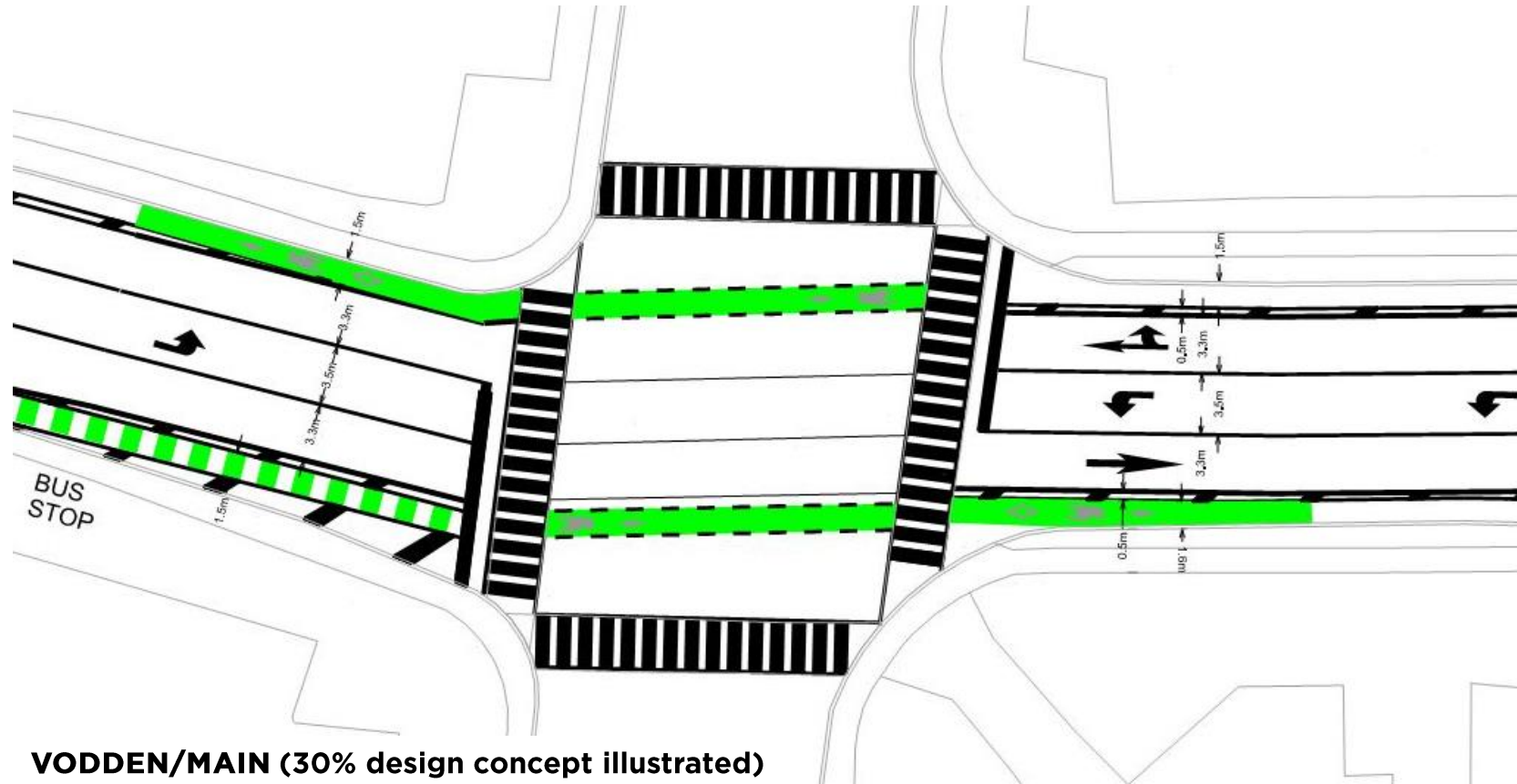

DESIGN HIGHLIGHTS

- **Road-diet treatment**
Remove 1 eastbound lane along Vodden
- **Improve intersection skew condition**
Design seeks to minimize the skew of this intersection by utilizing the hatched buffer to improve alignment of vehicle travel lanes

VODDEN/MAIN (30% design concept illustrated)

DESIGN CONSIDERATIONS

CROSSRIDE TREATMENTS

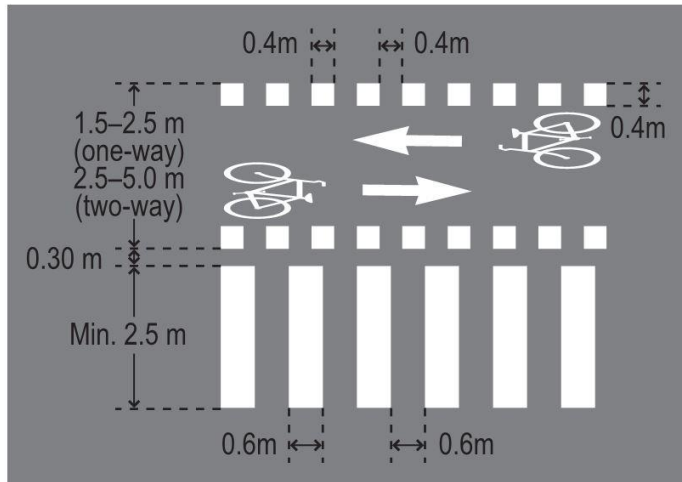

SEPARATE CROSSRIDE

Provides a separate space for pedestrians and cyclists and may be used at signalized and unsignalized locations.

- Howden/Hanover
- Howden/Dixie (regional intersection)

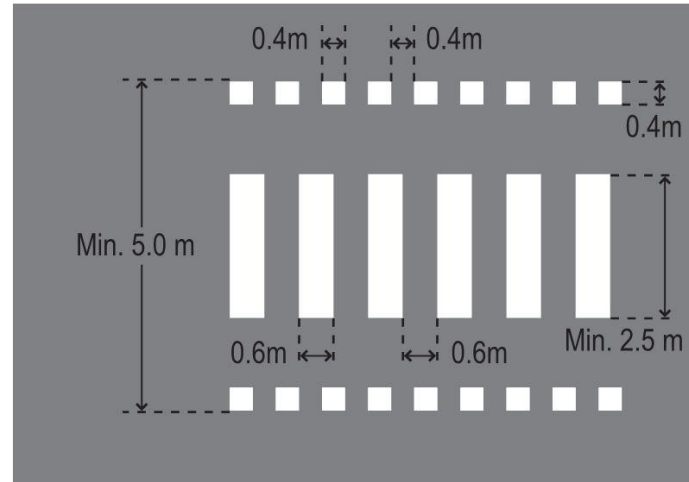

COMBINED CROSSRIDE

May be used at signalized and unsignalized locations where pedestrians and cyclists approach the crossing on a shared facility.

- Howden/Vodden
- Vodden/Ken Whillans

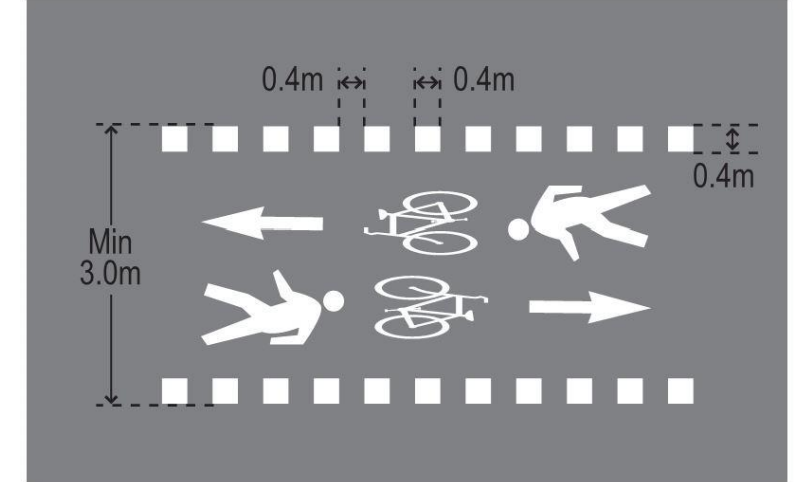

MIXED CROSSRIDE

Intended for low-volume unsignalized crossings, with pedestrians and cyclists operate in a shared space.

- Howden/Lindridge
- Howden/La France
- Howden/Heath

DESIGN CONSIDERATIONS

MAJOR DRIVEWAY TREATMENTS

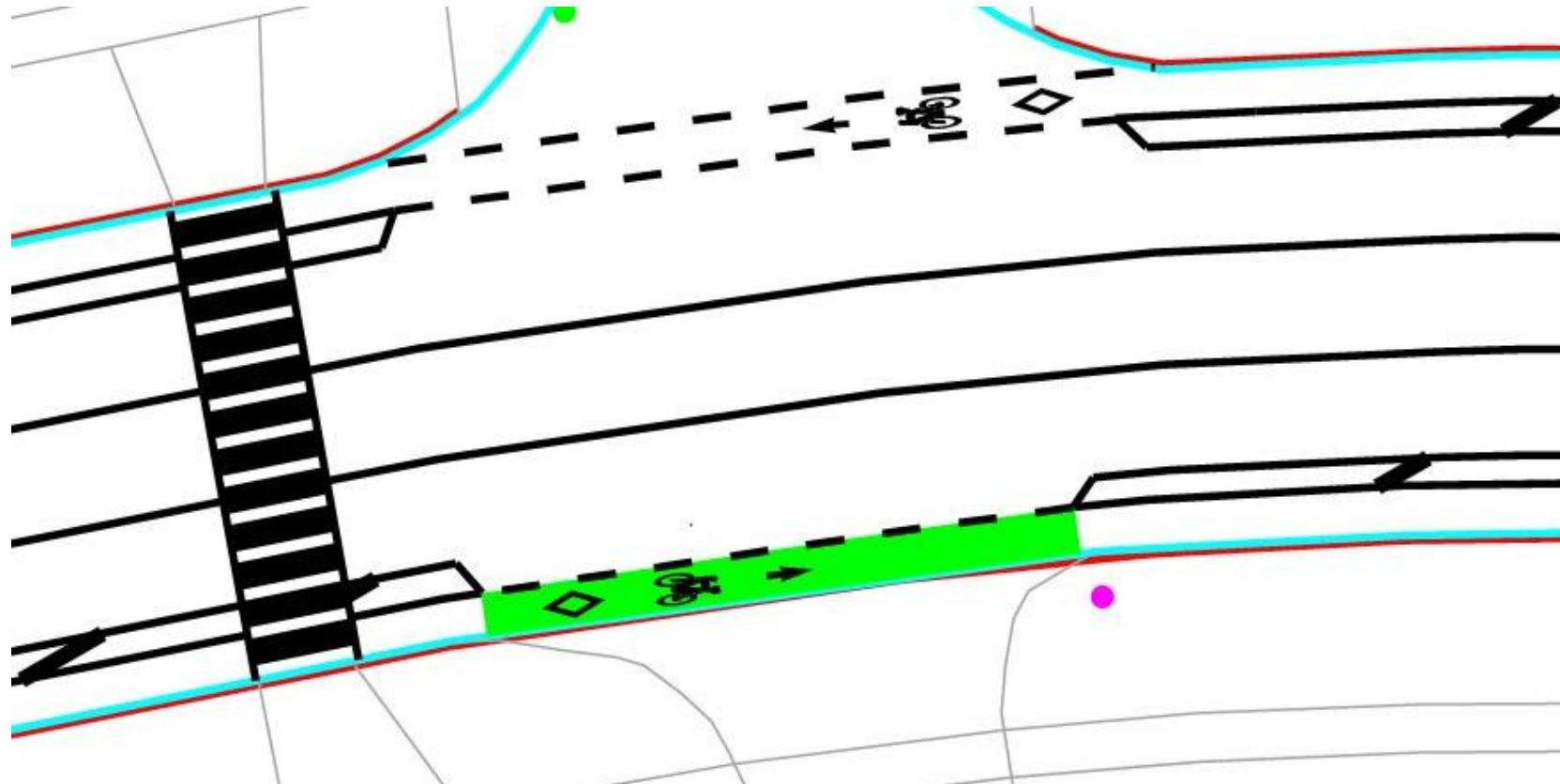

DESIGN HIGHLIGHTS (Commercial/Institutional Driveways)

- Directional arrow, bicycle stencil, and diamond
- Solid green surface treatment
- Dashed guide lines

DRIVEWAY AT LESTER B. PEARSON ELEMENTARY SCHOOL (30% design concept illustrated)

DESIGN CONSIDERATIONS

IN-BOULEVARD MULTI-USE PATH



DESIGN HIGHLIGHTS (Howden Boulevard Only)

- Williams Parkway – Hanover Road (1 side only)
- Existing 1.5 metre sidewalk to be replaced with 3.0 metre asphalt multi-use path
- Removal of 1 vehicle lane in each direction on Howden would result in significant vehicle queueing at select intersections

VODDEN STREET

EXISTING

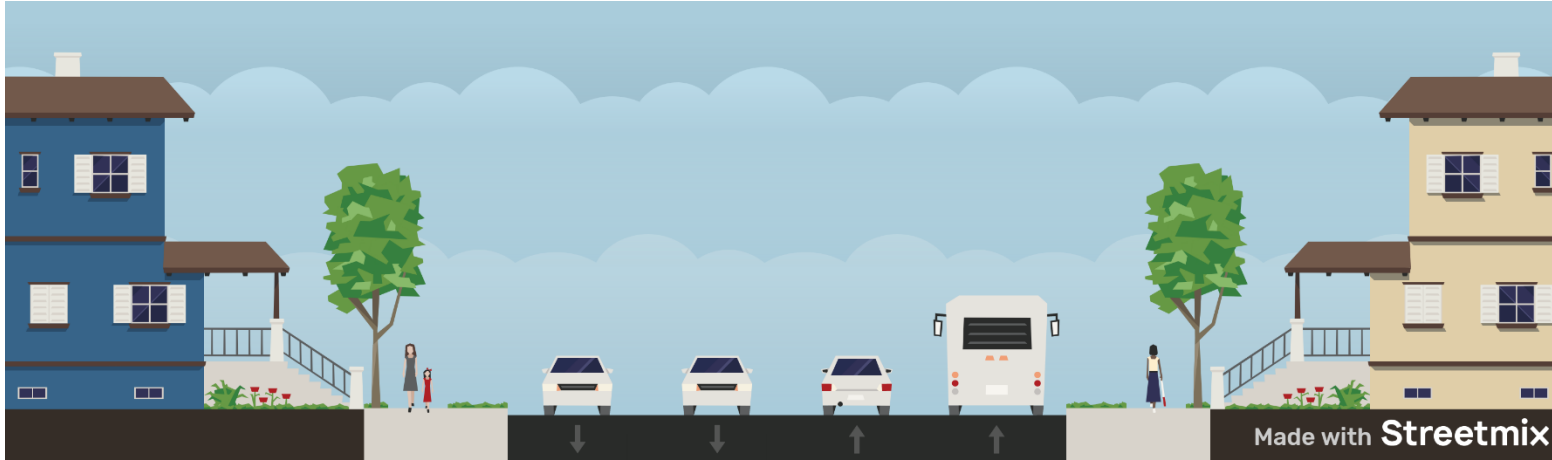

PROPOSED

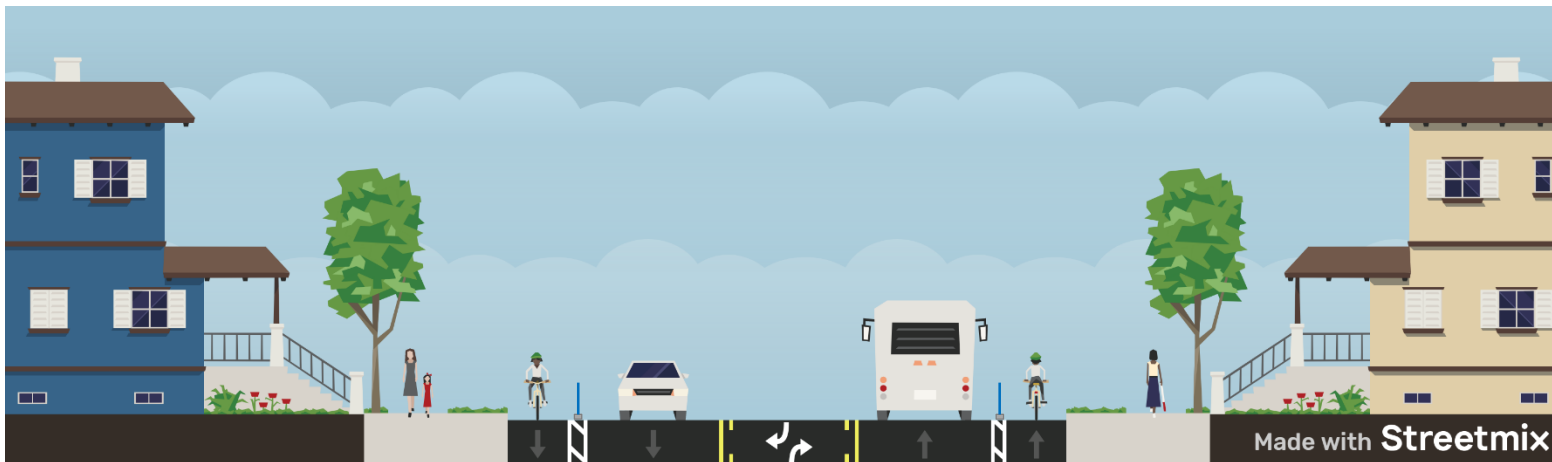

KEY CONSIDERATIONS

- **3.7KM corridor**
Isabella St. – Howden Blvd.
- **Transit Route**
Brampton Transit route 9
- **Highway 410 Crossing**
No highway interchange
- **Trail Connectivity**
Etobicoke Creek Rec. Trail
Esker Lake Rec. Trail
- **Emergency Services Corridor**
Brampton Fire Station 207



VODDEN/ARCHDEKIN FACING WEST (Concept Rendering)

HOWDEN BOULEVARD

EXISTING

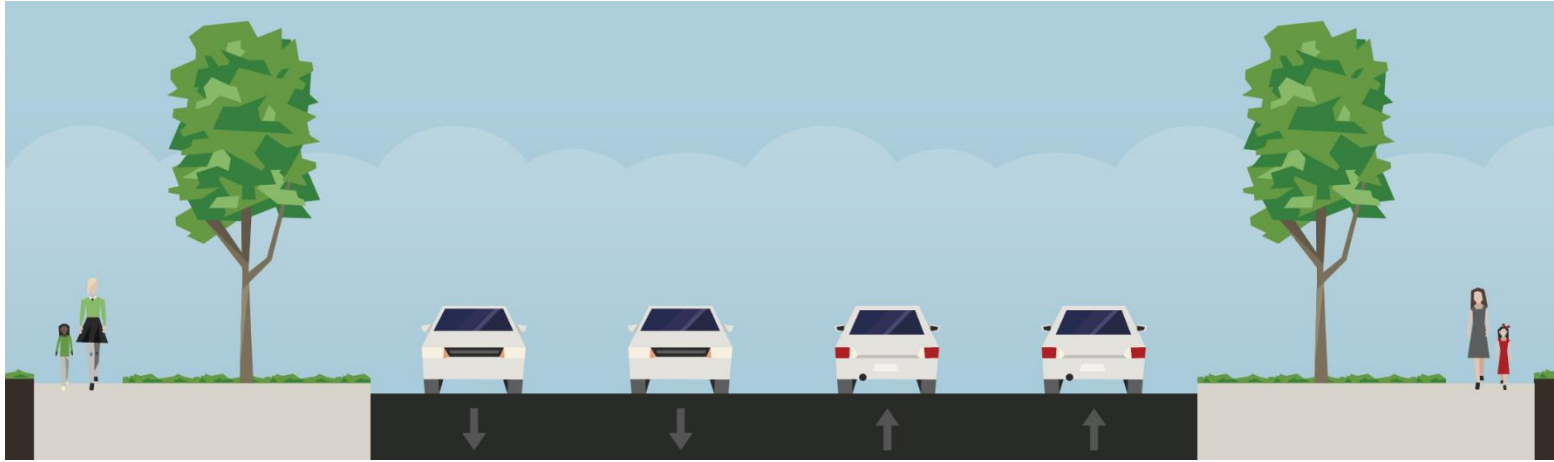

PROPOSED

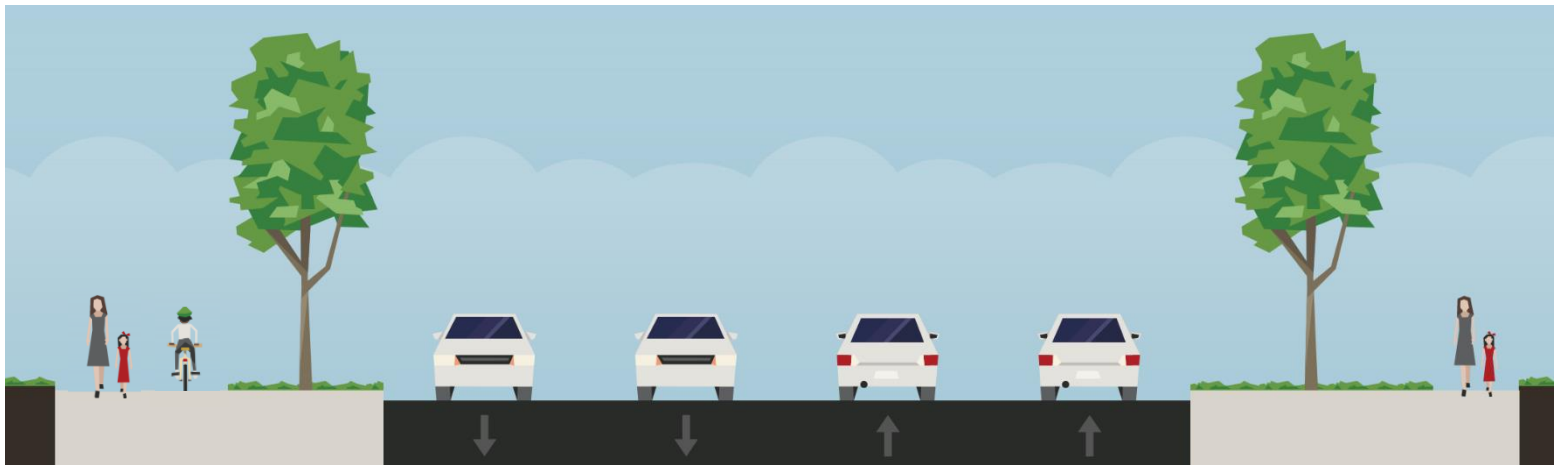

KEY CONSIDERATIONS

- **2.1KM corridor**
Williams Pkwy. – Central Park Dr.
- **In-Boulevard Multi-Use Path**
Williams Pkwy. – Hanover Rd.
- **On-Road Bike Lanes**
Hanover Rd. – Central Park Dr.
- **Transit Route**
Brampton Transit route 9 & 17
- **Schools along Corridor**
Lester B Pearson Elementary School
North Park Secondary School

HANOVER ROAD

EXISTING

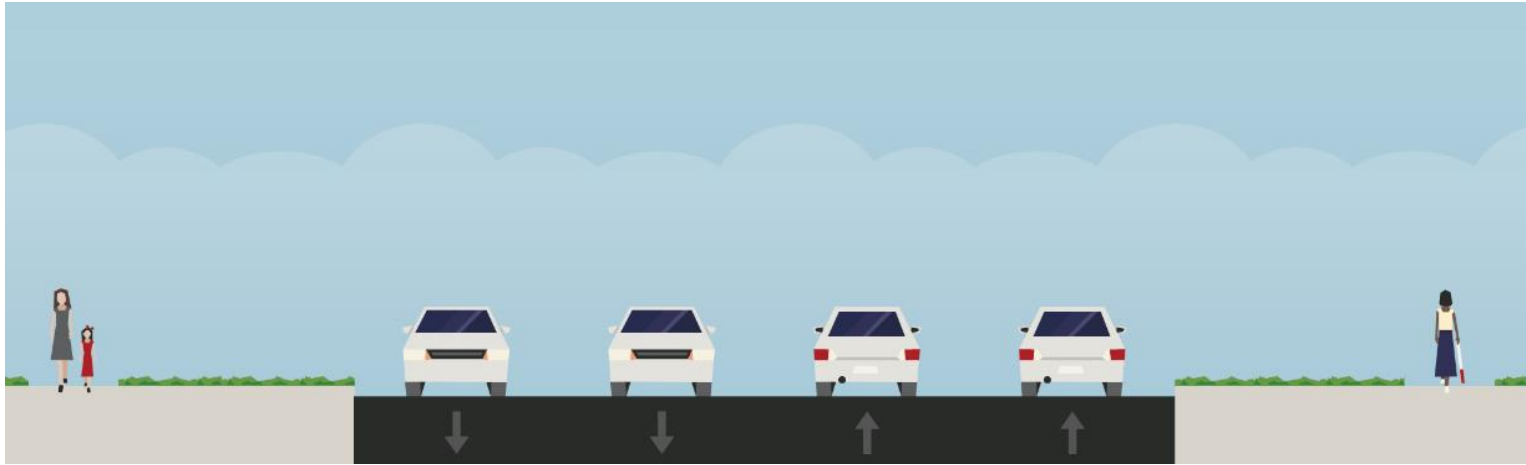

PROPOSED

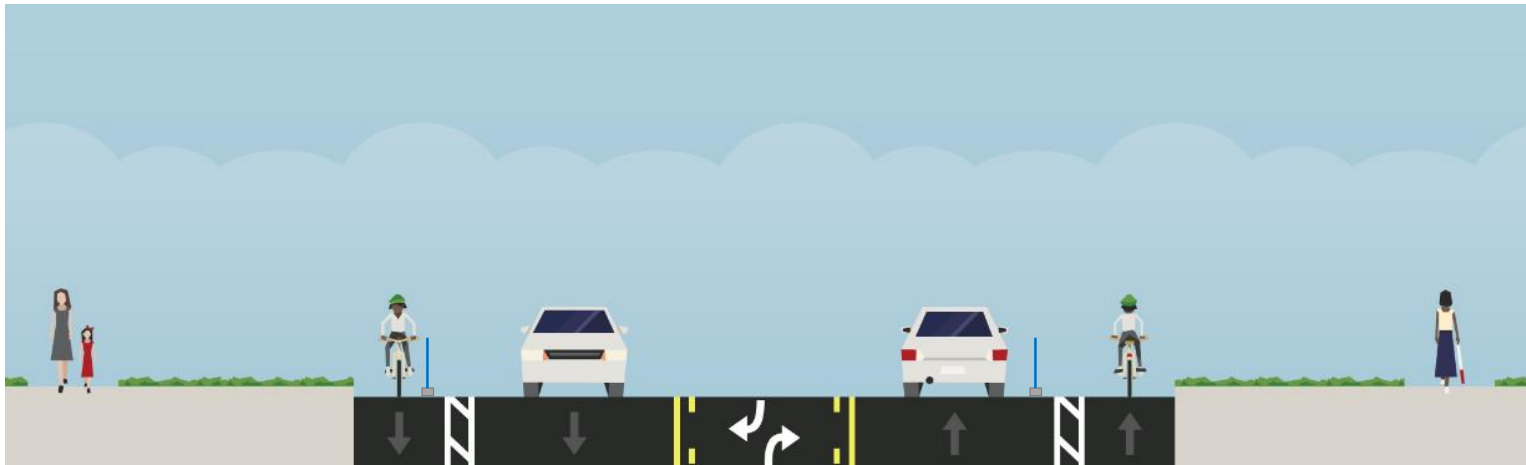

KEY CONSIDERATIONS

- **Hanover (1KM corridor)**
Howden Blvd. – Central Park Dr.
- **Transit Route**
Brampton Transit route 17
- **Access to Chinguacousy Park**
Major recreational and trail facilities
- **Elementary School**
Hanover Public School
- **High Density Residential Buildings**
Separated bike lanes accessible to a large number of residents

INTERIM BIKE LANES



INTERIM BIKE LANES

IMPLEMENTED
APRIL 2020

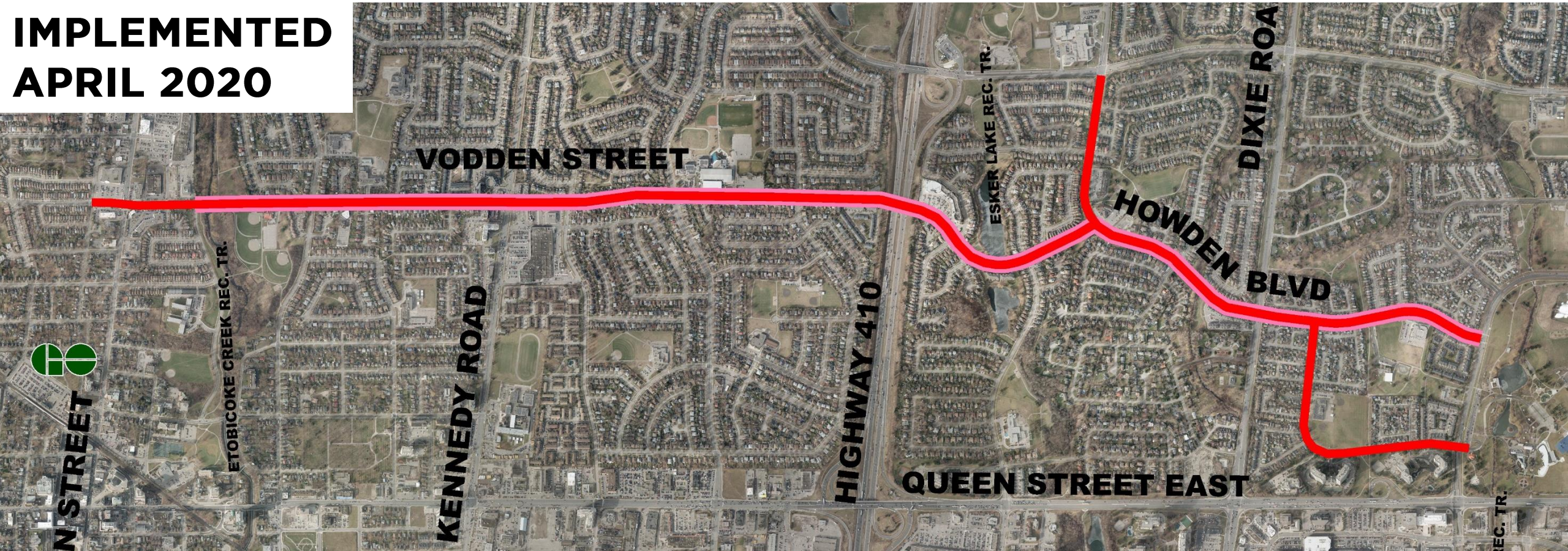

PROJECT TIMEFRAME

SUMMER 2020 Detailed design work scheduled to be completed

SUMMER/FALL 2020 Phased implementation to begin (road-diet pavement markings along Vodden Street, Howden Boulevard, and Hanover Road)

SPRING/SUMMER 2021 Implementation of precast concrete curbs and flexible bollards, and construction of Howden Boulevard multi-use path

PUBLIC CONSULTATION



METROQUEST SURVEY

Webpage to be live shortly, with a link on the City's project webpage.

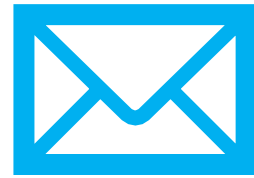

PROJECT POSTCARD

Brief project overview and study area map, mail to all addresses along east-west corridor.



COMMUNITY RIDE ALONG

Cancelled as a result of COVID-19.

PUBLIC CONSULTATION

METROQUEST ONLINE ENGAGEMENT

The screenshot displays a web-based interface for a public consultation exercise. The interface is divided into five vertical sections, numbered 1 to 5 from left to right: 1. WELCOME, 2. PRIORITY RANKING, 3. DESIGN ELEMENTS, 4. DESIGN TREATMENTS, and 5. THANK YOU. The current section is '2 What is important to you?'. At the top of this section, there are buttons for '? What to do' and 'Next Task'. Below the title, there is a list of six options for priority ranking, each in a rounded rectangular button. The options are: 'Add Separated Bike Lanes', 'Intersection Safety' (highlighted in yellow), 'Slower Traffic', 'Pedestrian/Cyclist Safety', 'Add Vehicle Turning Lanes', and 'Enhance Streetscaping'. Above the list, there is a text prompt: 'Order your top 3 items above this line' with up and down arrows. To the right of the list is a photograph of a city street intersection with green-painted bike lanes and crosswalks. Below the photo is a text box: 'Intersection Pavement Markings' followed by a paragraph: 'Make intersections safer by adding pavement markings to telling different road users where they are supposed to travel when they go through an intersection.' Below the text box is a 'Comment' button. At the bottom left of the interface is a 'Suggest another' button with a speech bubble icon. At the bottom right is a small red square icon with a white 'M'.

PRIORITY RANKING EXERCISE

- **Solicit priorities from participants**
Identify priorities among participants related to design considerations
- **Understand what is important**
Allows the project team to understand what participants value most and which considerations are priorities

PUBLIC CONSULTATION

METROQUEST ONLINE ENGAGEMENT

The screenshot displays the MetroQuest online engagement interface. At the top, a navigation bar includes a back arrow, a 'What to do' button, and a 'Next Task' button. Below this, a vertical sidebar on the left contains five numbered steps: 1. WELCOME, 2. PRIORITY RANKING, 3. Map your thoughts! (the active step), 4. DESIGN TREATMENTS, and 5. THANK YOU. The main map area shows a Google Map of Brampton, Ontario, with several colored lines (red, purple, blue) indicating design elements or routes. A legend at the top of the map area lists five categories: Safety Issues (bicycle icon), Speed Issues (speed limit sign icon), Crossing Issues (crossing sign icon), Streetscaping (tree icon), and General Comment (speech bubble icon). A text prompt above the legend reads 'Please drag and drop at least 3 markers on the map.' The map also shows various streets, including Main St N, Queen St E, and Rutherford Rd N, and landmarks like Bramalea City Centre.

INTERACTIVE MAPPING EXERCISE

- **Location-specific commenting**
Tool allows participants to pinpoint exact locations where they have experienced issues with safety, speeding, or crossing locations
- Allows participants to share intimate knowledge of the east-west corridor with project team based on lived experiences

PUBLIC CONSULTATION

METROQUEST ONLINE ENGAGEMENT

WELCOME 2 PRIORITY RANKING 3 DESIGN ELEMENTS 4 Proposed Design Features 5 THANK YOU

What to do Next Task

Bus Stops Multi-Use Path Concrete Barrier Curbs Intersection Markings Two-Way Centre Turn Lane

Bus Stops [More about this](#)

The number and location of bus stops along Vodden Street, Howden Boulevard, and Hanover Road will not change. Green pavement markings will be added to increase visibility for bike riders and transit operators at bus stops.



Curb length depends on context and design vehicle (30m shown as typical)

Please rate this image from 1 star (least preferred) to 5 stars (most preferred)

★ ★ ★ ★ ★

Previous Optional Comment Next

DESIGN TREATMENT PREFERENCES

- Presents participants with design treatments that have largely been decided upon and are being applied across the east-west corridor
- Better understand participants' views towards selected design treatments to identify whether major concerns exist
- Allows project team to respond to concerns with proposed design features and treatments

NEXT STEPS

We are looking for any feedback that you may have, as well as any considerations you'd like to share with the project team.

Please provide any feedback or questions to Nelson Cadete by **June 5th**.

CONTACT US

Nelson Cadete

Project Manager, Active Transportation
Planning & Development Services
City of Brampton

 905-874-2552

 nelson.cadete@brampton.ca

J. David McLaughlin

National Active Transportation Practice
Manager & Senior Project Manager
WSP

 905-882-7306

 dave.mclaughlin@wsp.com

THANK YOU!

QUESTIONS?

